

FOND DE CUVE A TÊTES ELLIPTIQUES ET À CONE DISHED & FLANGED ELLIPTICAL HEADS

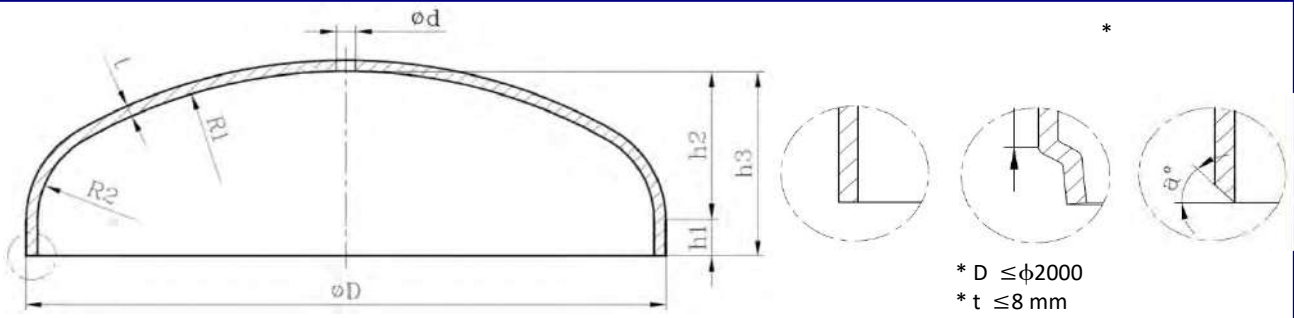

| φD mm | Dp mm | t mm | h2 mm | Volume L | mass kg/mm |
|-------|-------|------|-------|----------|------------|
| 550 | 701 | 2-10 | 135 | 20,2 | 3,1 |
| 600 | 760 | 2-10 | 148 | 26,4 | 3,6 |
| 650 | 820 | 2-10 | 161 | 33,8 | 4,2 |
| 700 | 879 | 2-14 | 173 | 42,3 | 4,8 |
| 750 | 938 | 2-14 | 186 | 52,3 | 5,5 |
| 800 | 997 | 2-14 | 199 | 63,6 | 6,2 |
| 850 | 1056 | 2-14 | 212 | 76,5 | 7,0 |
| 900 | 1115 | 2-14 | 224 | 91,0 | 7,8 |
| 950 | 1175 | 2-14 | 237 | 107,3 | 8,7 |
| 1000 | 1234 | 3-16 | 250 | 125,4 | 9,6 |
| 1050 | 1293 | 3-16 | 263 | 145,4 | 10,5 |
| 1100 | 1352 | 3-16 | 275 | 167,4 | 11,5 |
| 1150 | 1411 | 3-16 | 288 | 191,6 | 12,5 |
| 1200 | 1471 | 3-16 | 301 | 218,0 | 13,6 |
| 1250 | 1530 | 3-16 | 314 | 246,7 | 14,7 |
| 1300 | 1589 | 3-16 | 326 | 277,8 | 15,9 |
| 1350 | 1648 | 3-16 | 339 | 311,4 | 17,1 |
| 1400 | 1707 | 3-16 | 352 | 347,6 | 18,3 |
| 1450 | 1767 | 3-16 | 365 | 386,6 | 19,6 |
| 1500 | 1826 | 3-16 | 377 | 428,3 | 20,9 |
| 1550 | 1885 | 3-16 | 390 | 472,9 | 22,3 |
| 1600 | 1944 | 3-16 | 403 | 520,6 | 23,7 |
| 1650 | 2003 | 3-30 | 416 | 571,3 | 25,2 |
| 1700 | 2062 | 3-30 | 428 | 625,3 | 26,7 |
| 1750 | 2122 | 3-30 | 441 | 682,5 | 28,3 |
| 1800 | 2181 | 3-30 | 454 | 743,1 | 29,9 |
| 1850 | 2257 | 4-30 | 467 | 801,9 | 32,0 |
| 1900 | 2316 | 4-30 | 479 | 869,3 | 33,7 |
| 1950 | 2375 | 4-30 | 492 | 940,4 | 35,4 |
| 2000 | 2434 | 4-30 | 505 | 1015,2 | 37,2 |
| 2050 | 2493 | 4-30 | 518 | 1093,9 | 39,0 |
| 2100 | 2553 | 4-30 | 530 | 1176,6 | 40,9 |
| 2150 | 2612 | 4-30 | 543 | 1263,4 | 42,8 |
| 2200 | 2671 | 4-30 | 556 | 1354,3 | 44,8 |
| 2250 | 2730 | 4-30 | 569 | 1449,4 | 46,8 |
| 2300 | 2789 | 4-30 | 581 | 1548,9 | 48,9 |
| 2350 | 2849 | 4-30 | 594 | 1652,9 | 51,0 |
| 2400 | 2908 | 4-30 | 607 | 1761,4 | 53,1 |
| 2450 | 2967 | 4-30 | 620 | 1874,6 | 55,3 |
| 2500 | 3026 | 4-30 | 632 | 1992,5 | 57,5 |
| 2550 | 3085 | 4-30 | 645 | 2115,3 | 59,8 |
| 2600 | 3145 | 4-30 | 658 | 2243,0 | 62,1 |
| 2650 | 3204 | 4-30 | 671 | 2375,7 | 64,5 |
| 2700 | 3263 | 4-30 | 683 | 2513,6 | 66,9 |
| 2750 | 3322 | 4-30 | 696 | 2668,4 | 69,3 |

| φD mm | Dp mm | t mm | h2 mm | Volume L | mass kg/mm |
|-------|-------|------|-------|----------|------------|
| 2800 | 3381 | 4-30 | 709 | 2817,2 | 71,8 |
| 2850 | 3440 | 4-30 | 722 | 2971,5 | 74,3 |
| 2900 | 3500 | 4-30 | 734 | 3131,4 | 76,9 |
| 2950 | 3559 | 4-30 | 747 | 3296,8 | 79,5 |
| 3000 | 3618 | 5-30 | 760 | 3468,0 | 82,2 |
| 3050 | 3677 | 5-28 | 773 | 3645,1 | 84,9 |
| 3100 | 3736 | 5-28 | 785 | 3828,0 | 87,7 |
| 3150 | 3796 | 5-28 | 798 | 4017,0 | 90,5 |
| 3200 | 3855 | 5-28 | 811 | 4212,1 | 93,3 |
| 3250 | 3914 | 5-28 | 824 | 4413,4 | 96,2 |
| 3300 | 3973 | 5-28 | 836 | 4621,0 | 99,1 |
| 3350 | 4032 | 5-28 | 849 | 4835,1 | 102,1 |
| 3400 | 4092 | 5-28 | 862 | 5055,6 | 105,1 |
| 3450 | 4151 | 5-28 | 875 | 5282,8 | 108,2 |
| 3500 | 4210 | 5-28 | 887 | 5516,6 | 111,3 |
| 3550 | 4269 | 5-28 | 900 | 5757,3 | 114,5 |
| 3600 | 4328 | 5-28 | 913 | 6004,8 | 117,6 |
| 3650 | 4387 | 5-28 | 926 | 6259,4 | 120,9 |
| 3700 | 4447 | 5-28 | 938 | 6521,0 | 124,2 |
| 3750 | 4506 | 5-28 | 951 | 6789,9 | 127,5 |
| 3800 | 4565 | 5-28 | 964 | 7066,0 | 130,9 |
| 3850 | 4624 | 5-28 | 977 | 7349,5 | 134,3 |
| 3900 | 4683 | 5-28 | 989 | 7640,5 | 137,7 |
| 3950 | 4743 | 5-28 | 1002 | 7939,1 | 141,2 |
| 4000 | 4802 | 5-28 | 1015 | 8245,3 | 144,8 |



Note: ● t = Épaisseur de la matière première / Raw material thickness ● Dp = diamètre rondelle / Diameter of blank disc
 ● Consultez notre commercial pour tolérances dimensionnelles. / Please contact our sales team for dimension tolerances.

Trabzon TURQUIE

T: +90 505 130 2931 | www.yorkamgroup.com | info@yorkamgroup.com

FOND DE CUVE A TÊTES ELLIPTIQUES ET À CONE
DISHED & FLANGED ELLIPTICAL HEADS

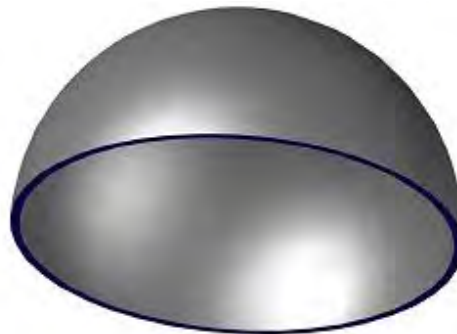
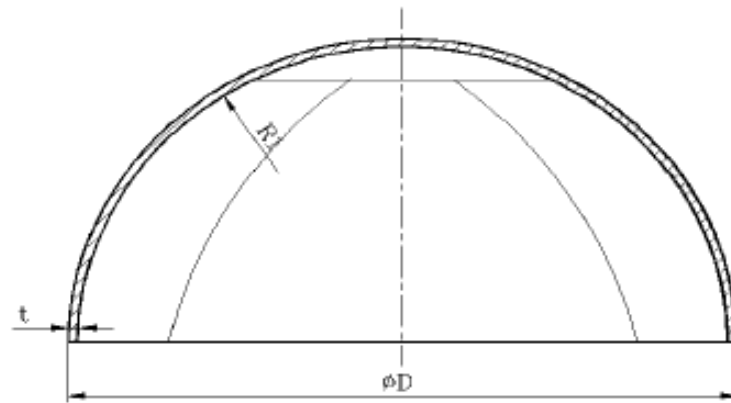
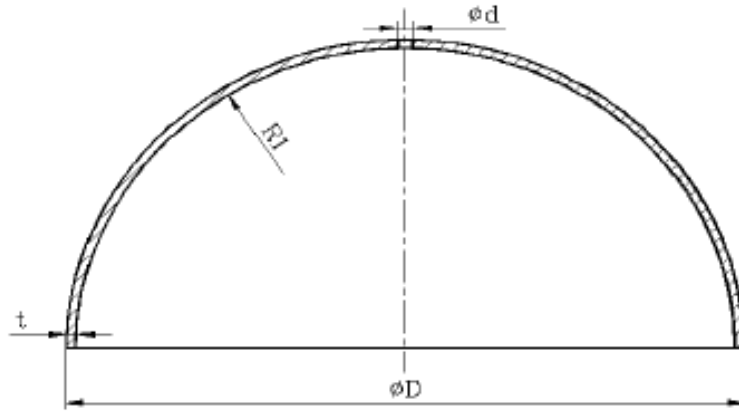

$D = \text{max. } 32000 \text{ mm (multiple pieces)}$

$D = \text{max. } 1200 \text{ mm (unique piece)}$

$R1 = 0,5 \times D$

$t = \text{max. } 50 \text{ mm}$

$\text{Mass} = (Dp^2 \times 0,785 \times 8/1000000) \times t$

* t = Épaisseur matière première - Raw material thickness

* Dp = diamètre rondelle - Diameter of blank disc

FOND DE CUVE A TÊTES ELLIPTIQUES ET À CONE
DISHED & FLANGED ELLIPTICAL HEADS

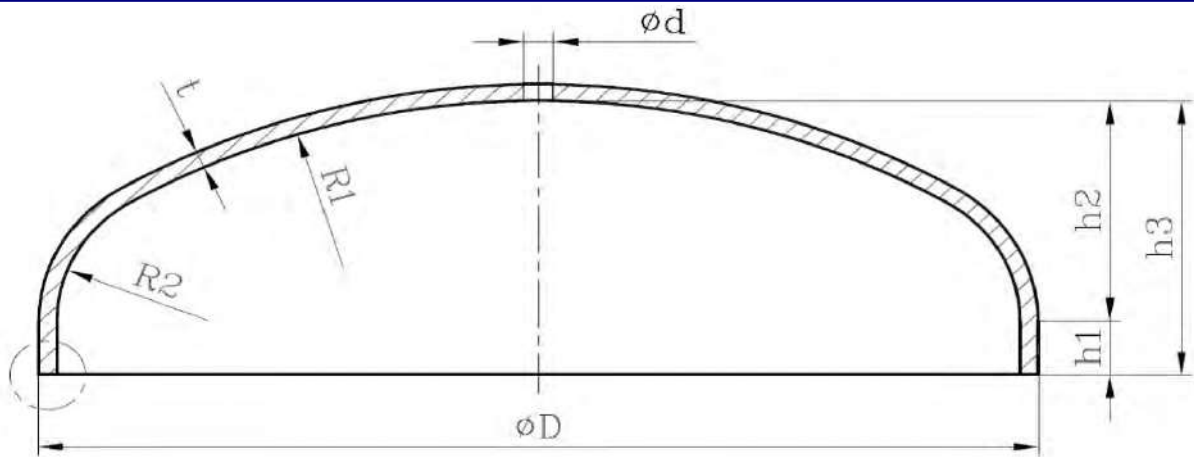

DETAIL - A

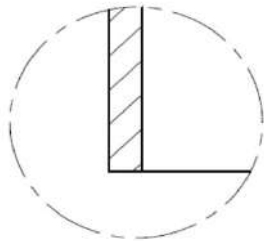

DETAIL - B

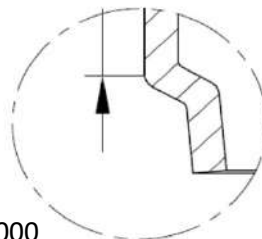

DETAIL - C

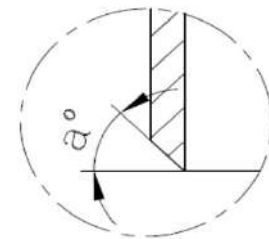

* $D \leq \phi 2000$
 $t \leq 8 \text{ mm}$

DIN 28 013

$R1 = 0,8 \times D$

$R2 = 0,154 \times D$

$h1 \geq 3 \times t$

$h2 = 0,255 \times D - 0,635 \times t$

Volume($h1=0$) $\approx 0,1298(D-2t)^3$

Mass = $(Dp^2 \times 0,785 \times 8/1000000) \times t$

* t = Épaisseur matière première - Raw material thickness

* Dp = diamètre rondelle - Diameter of blank disc

FOND DE CUVE A TÊTES ELLIPTIQUES ET À CONE
DISHED & FLANGED ELLIPTICAL HEADS

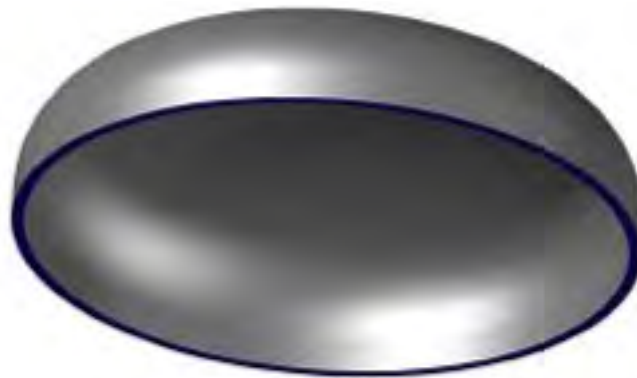
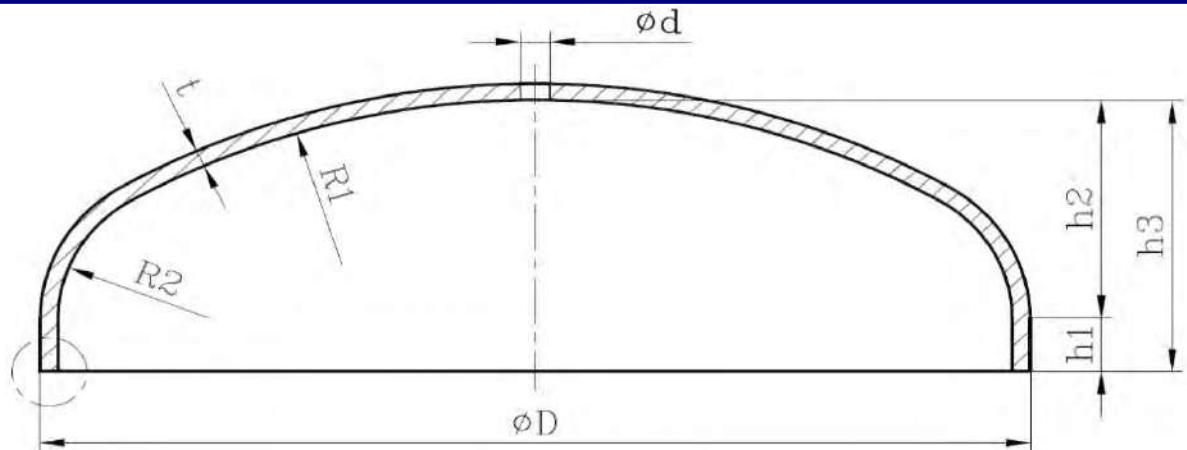

DETAIL - A

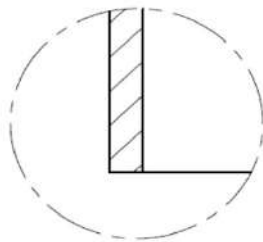

DETAIL - B

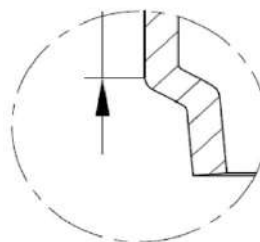

DETAIL - C

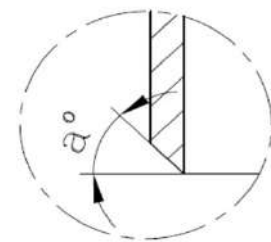

* $D \leq \phi 2000$
 ≤ 8 mm

ASME 2:1

$D = \text{max.} 5000$ mm

$R1 = 0,9 \times D$

$R2 = 0,17 \times D$

$t = \text{max.} 25$ mm

$\text{Mass} = (Dp^2 \times 0,785 \times 8/1000000) \times t$

* t = Épaisseur matière première - Raw material thickness

* Dp = diamètre rondelle - Diameter of blank disc

FOND DE CUVE A TÊTES ELLIPTIQUES ET À CONE
DISHED & FLANGED ELLIPTICAL HEADS

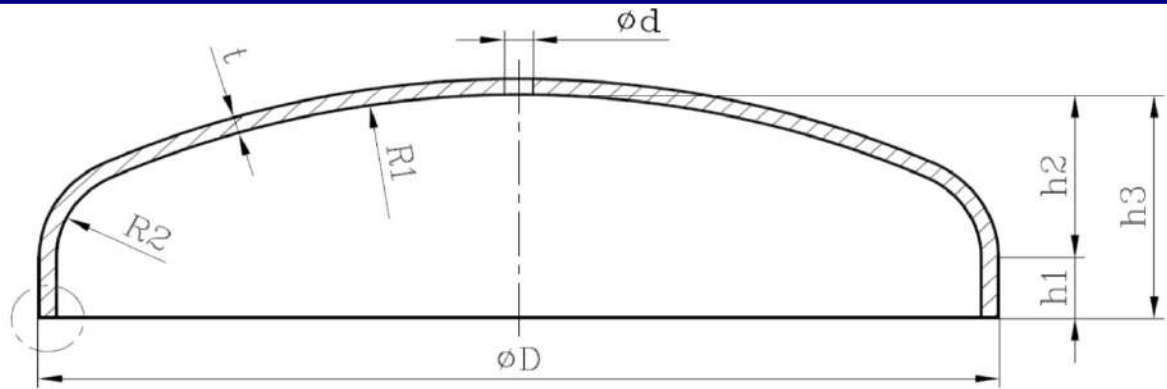

DETAIL - A

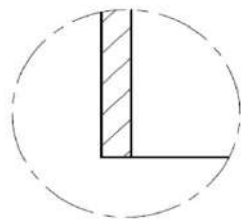

DETAIL - B

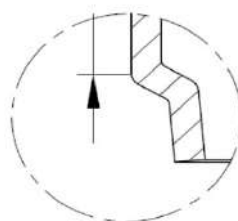

DETAIL - C

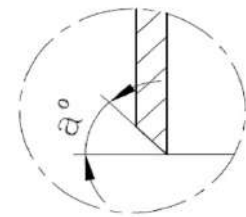

*D ≤ φ2000
 ≤8 mm

DIN 28 011

$R1 = D$

$R2 = 0,1 \times D$

$h1 \geq 3,5 \times t$

$h2 = 0,1935 \times D - 0,455 \times t$

$\text{Volume}(h1=0) \approx 0,1(D-2t)^3$

$\text{Mass} = (Dp^2 \times 0,785 \times 8/1000000) \times t$

*t=Épaisseur matière première - Raw material thickness

*Dp = diamètre rondelle - Diameter of blank disc

FOND DE CUVE A TÊTES ELLIPTIQUES ET À CONE DISHED & FLANGED ELLIPTICAL HEADS

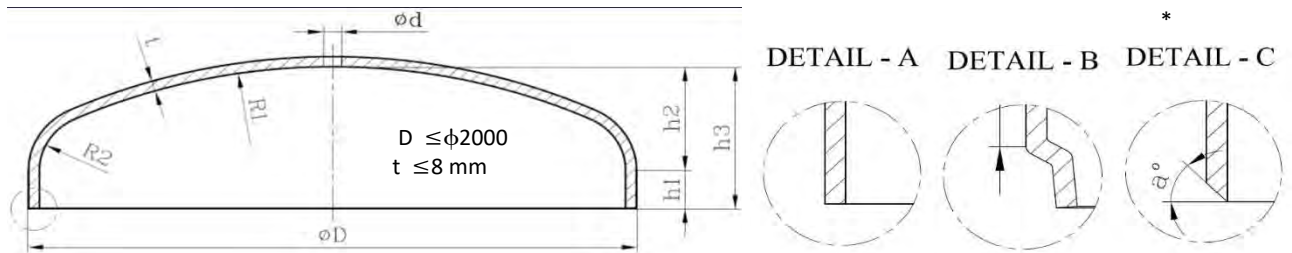

| ϕD mm | D_p mm | t mm | h2 mm | Volume L | mass kg/mm |
|----------------|-------------|---------|----------|-------------|---------------|
| 550 | 663 | 2-12 | 103 | 15,2 | 2,8 |
| 600 | 719 | 2-12 | 112 | 19,9 | 3,2 |
| 650 | 775 | 2-12 | 122 | 25,5 | 3,8 |
| 700 | 830 | 2-16 | 132 | 32,0 | 4,3 |
| 750 | 886 | 2-16 | 141 | 39,5 | 4,9 |
| 800 | 942 | 2-16 | 151 | 48,2 | 5,6 |
| 850 | 998 | 2-16 | 161 | 58,0 | 6,2 |
| 900 | 1053 | 2-16 | 171 | 69,1 | 7,0 |
| 950 | 1109 | 2-16 | 180 | 81,5 | 7,7 |
| 1000 | 1165 | 3-18 | 190 | 95,3 | 8,5 |
| 1050 | 1237 | 3-18 | 200 | 110,6 | 9,6 |
| 1100 | 1293 | 3-18 | 209 | 127,4 | 10,5 |
| 1150 | 1349 | 3-18 | 219 | 145,8 | 11,4 |
| 1200 | 1404 | 3-18 | 229 | 166,0 | 12,4 |
| 1250 | 1460 | 3-18 | 238 | 187,9 | 13,4 |
| 1300 | 1516 | 3-18 | 248 | 211,7 | 14,4 |
| 1350 | 1572 | 3-18 | 258 | 237,4 | 15,5 |
| 1400 | 1627 | 3-18 | 267 | 265,1 | 16,6 |
| 1450 | 1683 | 3-18 | 277 | 294,9 | 17,8 |
| 1500 | 1739 | 3-18 | 287 | 326,8 | 19,0 |
| 1550 | 1794 | 3-18 | 296 | 361,0 | 20,2 |
| 1600 | 1850 | 3-18 | 306 | 397,4 | 21,5 |
| 1650 | 1906 | 3-30 | 316 | 436,3 | 22,8 |
| 1700 | 1962 | 3-30 | 325 | 477,6 | 24,2 |
| 1750 | 2017 | 3-30 | 335 | 521,4 | 25,6 |
| 1800 | 2073 | 3-30 | 345 | 567,8 | 27,0 |
| 1850 | 2129 | 4-30 | 354 | 616,9 | 28,5 |
| 1900 | 2185 | 4-30 | 364 | 668,7 | 30,0 |
| 1950 | 2240 | 4-30 | 374 | 723,4 | 31,5 |
| 2000 | 2296 | 4-30 | 383 | 781,0 | 33,1 |
| 2050 | 2352 | 4-30 | 393 | 841,5 | 34,7 |
| 2100 | 2407 | 4-30 | 403 | 905,1 | 36,4 |
| 2150 | 2463 | 4-30 | 412 | 971,8 | 38,1 |
| 2200 | 2519 | 4-30 | 422 | 1041,7 | 39,8 |
| 2250 | 2575 | 4-30 | 432 | 1114,9 | 41,6 |
| 2300 | 2630 | 4-30 | 441 | 1191,5 | 43,5 |
| 2350 | 2686 | 4-30 | 451 | 1271,5 | 45,3 |
| 2400 | 2742 | 4-30 | 461 | 1354,9 | 47,2 |
| 2450 | 2798 | 4-30 | 470 | 1442,0 | 49,1 |
| 2500 | 2853 | 4-30 | 480 | 1532,7 | 51,1 |
| 2550 | 2909 | 4-30 | 490 | 1627,1 | 53,1 |
| 2600 | 2981 | 4-30 | 499 | 1725,4 | 55,8 |
| 2650 | 3037 | 4-30 | 509 | 1827,5 | 57,9 |
| 2700 | 3093 | 4-30 | 519 | 1933,5 | 60,1 |
| 2750 | 3149 | 4-30 | 528 | 2043,6 | 62,3 |
| 2800 | 3204 | 4-30 | 538 | 2157,8 | 64,5 |

| ϕD mm | D_p mm | t mm | h2 mm | Volume L | mass kg/mm |
|----------------|-------------|---------|----------|-------------|---------------|
| 2850 | 3260 | 4-30 | 548 | 2276,1 | 66,7 |
| 2900 | 3316 | 4-30 | 558 | 2398,8 | 69,0 |
| 2950 | 3372 | 4-30 | 567 | 2525,7 | 71,4 |
| 3000 | 3427 | 5-30 | 577 | 2657,0 | 73,8 |
| 3050 | 3483 | 5-30 | 587 | 2792,8 | 76,2 |
| 3100 | 3539 | 5-30 | 596 | 2933,2 | 78,6 |
| 3150 | 3594 | 5-30 | 606 | 3078,2 | 81,1 |
| 3200 | 3650 | 5-30 | 616 | 3227,9 | 83,7 |
| 3250 | 3706 | 5-30 | 625 | 3382,4 | 86,2 |
| 3300 | 3762 | 5-30 | 635 | 3541,7 | 88,9 |
| 3350 | 3817 | 5-30 | 645 | 3705,9 | 91,5 |
| 3400 | 3873 | 5-30 | 654 | 3875,2 | 94,2 |
| 3450 | 3929 | 5-30 | 664 | 4049,5 | 96,9 |
| 3500 | 4001 | 5-30 | 674 | 4229,0 | 100,5 |
| 3550 | 4057 | 5-30 | 683 | 4413,7 | 103,4 |
| 3600 | 4113 | 5-30 | 693 | 4603,7 | 106,2 |
| 3650 | 4168 | 5-30 | 703 | 4799,0 | 109,1 |
| 3700 | 4224 | 5-30 | 712 | 4999,9 | 112,1 |
| 3750 | 4280 | 5-30 | 722 | 5206,2 | 115,0 |
| 3800 | 4336 | 5-30 | 732 | 5418,2 | 118,1 |
| 3850 | 4391 | 5-30 | 741 | 5635,8 | 121,1 |
| 3900 | 4447 | 5-30 | 751 | 5859,2 | 124,2 |
| 3950 | 4503 | 5-30 | 761 | 6088,4 | 127,3 |
| 4000 | 4559 | 5-30 | 770 | 6323,5 | 130,5 |
| 4050 | 4614 | 5-30 | 780 | 6564,6 | 133,7 |
| 4100 | 4670 | 5-30 | 790 | 6811,7 | 137,0 |
| 4150 | 4726 | 5-30 | 799 | 7065,0 | 140,3 |
| 4200 | 4782 | 5-30 | 809 | 7324,5 | 143,6 |
| 4250 | 4837 | 5-30 | 819 | 7590,2 | 146,9 |
| 4300 | 4893 | 5-30 | 828 | 7862,3 | 150,3 |
| 4350 | 4949 | 5-30 | 838 | 8140,8 | 153,8 |
| 4400 | 5004 | 5-30 | 848 | 8425,8 | 157,3 |
| 4450 | 5060 | 5-30 | 857 | 8717,4 | 160,8 |
| 4500 | 5116 | 5-30 | 867 | 9015,6 | 164,4 |
| 4550 | 5172 | 5-30 | 877 | 9320,6 | 168,0 |
| 4600 | 5227 | 5-30 | 886 | 9632,4 | 171,6 |
| 4650 | 5283 | 5-30 | 896 | 9951,0 | 175,3 |
| 4700 | 5339 | 5-30 | 906 | 10276,6 | 179,0 |
| 4750 | 5395 | 5-30 | 915 | 10609,3 | 182,8 |
| 4800 | 5450 | 5-30 | 925 | 10949,0 | 186,5 |
| 4850 | 5506 | 5-30 | 935 | 11295,9 | 190,4 |
| 4900 | 5562 | 5-30 | 945 | 11650,0 | 194,3 |
| 5000 | 5673 | 5-30 | 964 | 12380,4 | 202,1 |
| 5100 | 5785 | 5-30 | 983 | 13078,0 | 210,2 |
| 5200 | 5896 | 5-30 | 1003 | 13867,0 | 218,3 |

Note: • t = Épaisseur de la matière première / Raw material thickness • D_p = diamètre rondelle / Diameter of blank disc
 • Consultez notre commercial pour tolérances dimensionnelles. / Please contact our sales team for dimension tolerances.

FOND DE CUVE A TÊTES ELLIPTIQUES ET À CONE
DISHED & FLANGED ELLIPTICAL HEADS

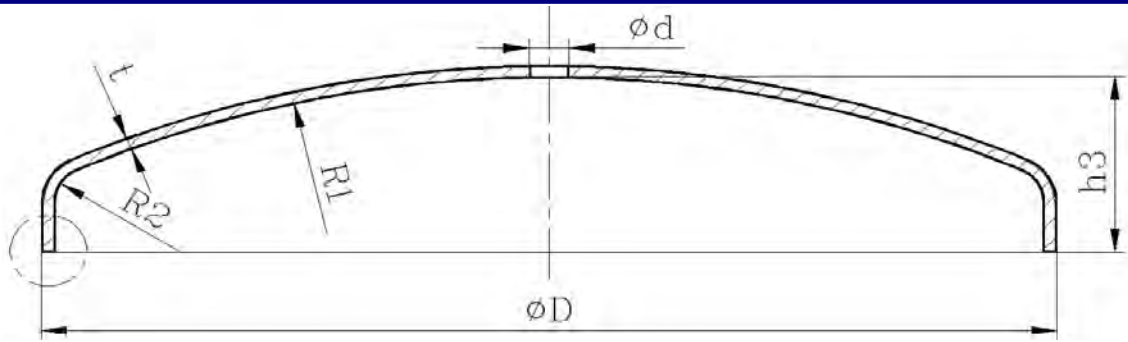

DETAIL - A

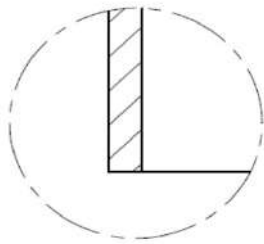

DETAIL - B

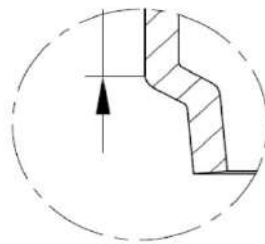

DETAIL - C

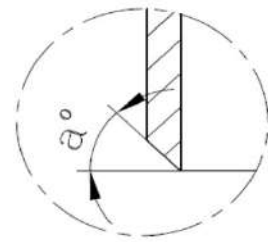

* $D \leq \phi 2000$
* $t \leq 8 \text{ mm}$

$$R1 = 1,15 \times D$$

$$R2 = 0,05 \times D$$

$$h1 \geq 3 \times t$$

$$h2 = 0,153 \times D - 0,455 \times t$$

$$h3 = h1 + h2$$

$$\text{Volume}(h1=0) \approx 0,607(D-2t)^3$$

$$\text{Mass} = (Dp^2 \times 0,785 \times 8/1000000) \times t$$

*t=Épaisseur matière première - Raw material thickness

*Dp = diamètre rondelle - Diameter of blank disc

FOND DE CUVE A BAS SPHERIQUE DISHED & FLANGED ELLIPTICAL HEADS

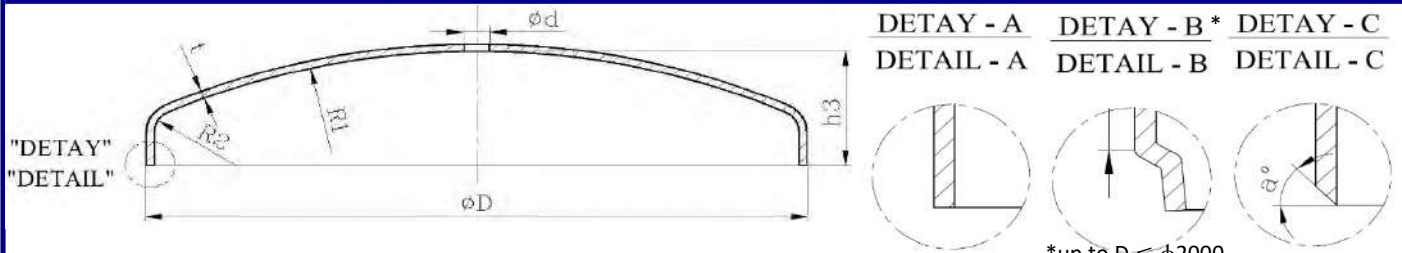

* up to $D \leq \phi 2000$
and $t \leq 8$ mm

| ϕD mm | Dp mm | t mm | h2 mm | Volume L | mass kg/mm |
|----------------|-------------|---------|----------|-------------|---------------|
| 550 | 632 | 2-12 | 84 | 9,2 | 2,5 |
| 600 | 684 | 2-12 | 92 | 12,1 | 2,9 |
| 650 | 737 | 2-12 | 99 | 15,5 | 3,4 |
| 700 | 790 | 2-16 | 107 | 19,4 | 3,9 |
| 750 | 843 | 2-16 | 115 | 24,0 | 4,5 |
| 800 | 896 | 2-16 | 122 | 29,3 | 5,0 |
| 850 | 949 | 2-16 | 130 | 35,2 | 5,7 |
| 900 | 1002 | 2-16 | 138 | 41,9 | 6,3 |
| 950 | 1054 | 2-16 | 145 | 49,5 | 7,0 |
| 1000 | 1107 | 3-18 | 153 | 57,8 | 7,7 |
| 1050 | 1177 | 3-18 | 161 | 67,1 | 8,7 |
| 1100 | 1230 | 3-18 | 168 | 77,3 | 9,5 |
| 1150 | 1283 | 3-18 | 176 | 88,5 | 10,3 |
| 1200 | 1335 | 3-18 | 184 | 100,7 | 11,2 |
| 1250 | 1388 | 3-18 | 191 | 114,1 | 12,1 |
| 1300 | 1441 | 3-18 | 199 | 128,5 | 13,0 |
| 1350 | 1494 | 3-18 | 207 | 144,1 | 14,0 |
| 1400 | 1547 | 3-18 | 214 | 160,9 | 15,0 |
| 1450 | 1600 | 3-18 | 222 | 179,0 | 16,1 |
| 1500 | 1653 | 3-18 | 230 | 198,4 | 17,2 |
| 1550 | 1705 | 3-18 | 237 | 219,1 | 18,3 |
| 1600 | 1758 | 3-18 | 245 | 241,2 | 19,4 |
| 1650 | 1811 | 3-30 | 252 | 264,8 | 20,6 |
| 1700 | 1864 | 3-30 | 260 | 289,9 | 21,8 |
| 1750 | 1917 | 3-30 | 268 | 316,5 | 23,1 |
| 1800 | 1970 | 3-30 | 275 | 344,6 | 24,4 |
| 1850 | 2023 | 4-30 | 283 | 374,4 | 25,7 |
| 1900 | 2075 | 4-30 | 291 | 405,9 | 27,1 |
| 1950 | 2128 | 4-30 | 298 | 439,1 | 28,4 |
| 2000 | 2181 | 4-30 | 306 | 474,0 | 29,9 |
| 2050 | 2234 | 4-30 | 314 | 510,8 | 31,3 |
| 2100 | 2287 | 4-30 | 321 | 549,4 | 32,8 |
| 2150 | 2340 | 4-30 | 329 | 589,9 | 34,4 |
| 2200 | 2393 | 4-30 | 337 | 632,3 | 36,0 |
| 2250 | 2446 | 4-30 | 344 | 676,8 | 37,6 |
| 2300 | 2498 | 4-30 | 352 | 723,2 | 39,2 |
| 2350 | 2551 | 4-30 | 360 | 771,8 | 40,9 |
| 2400 | 2604 | 4-30 | 367 | 822,4 | 42,6 |
| 2450 | 2657 | 4-30 | 375 | 875,3 | 44,3 |
| 2500 | 2710 | 4-30 | 383 | 930,3 | 46,1 |
| 2550 | 2763 | 4-30 | 390 | 987,7 | 47,9 |
| 2600 | 2832 | 4-30 | 398 | 1047,3 | 50,4 |
| 2650 | 2885 | 4-30 | 405 | 1109,3 | 52,3 |
| 2700 | 2938 | 4-30 | 413 | 1173,6 | 54,2 |
| 2750 | 2991 | 4-30 | 421 | 1240,5 | 56,2 |
| 2800 | 3044 | 4-30 | 428 | 1309,8 | 58,2 |

| ϕD mm | Dp mm | t mm | h2 mm | Volume L | mass kg/mm |
|----------------|-------------|---------|----------|-------------|---------------|
| 2850 | 3097 | 4-30 | 436 | 1381,6 | 60,2 |
| 2900 | 3149 | 4-30 | 444 | 1456,0 | 62,3 |
| 2950 | 3202 | 4-30 | 451 | 1533,1 | 64,4 |
| 3000 | 3255 | 5-30 | 459 | 1612,8 | 66,5 |
| 3050 | 3308 | 5-30 | 467 | 1695,3 | 68,7 |
| 3100 | 3361 | 5-30 | 474 | 1780,5 | 70,9 |
| 3150 | 3414 | 5-30 | 482 | 1868,5 | 73,2 |
| 3200 | 3467 | 5-30 | 490 | 1959,3 | 75,5 |
| 3250 | 3519 | 5-30 | 497 | 2053,1 | 77,8 |
| 3300 | 3572 | 5-30 | 505 | 2149,8 | 80,1 |
| 3350 | 3625 | 5-30 | 513 | 2249,5 | 82,5 |
| 3400 | 3678 | 5-30 | 520 | 2352,2 | 85,0 |
| 3450 | 3731 | 5-30 | 528 | 2458,0 | 87,4 |
| 3500 | 3800 | 5-30 | 536 | 2567,0 | 90,7 |
| 3550 | 3853 | 5-30 | 543 | 2679,1 | 93,2 |
| 3600 | 3906 | 5-30 | 551 | 2794,4 | 95,8 |
| 3650 | 3959 | 5-30 | 558 | 2913,0 | 98,4 |
| 3700 | 4012 | 5-30 | 566 | 3034,9 | 101,1 |
| 3750 | 4065 | 5-30 | 574 | 3160,2 | 103,8 |
| 3800 | 4118 | 5-30 | 581 | 3288,8 | 106,5 |
| 3850 | 4170 | 5-30 | 589 | 3420,9 | 109,2 |
| 3900 | 4223 | 5-30 | 597 | 3556,5 | 112,0 |
| 3950 | 4276 | 5-30 | 604 | 3695,7 | 114,8 |
| 4000 | 4329 | 5-30 | 612 | 3838,4 | 117,7 |
| 4050 | 4382 | 5-30 | 620 | 3984,7 | 120,6 |
| 4100 | 4435 | 5-30 | 627 | 4134,7 | 123,5 |
| 4150 | 4488 | 5-30 | 635 | 4288,4 | 126,5 |
| 4200 | 4540 | 5-30 | 643 | 4445,9 | 129,5 |
| 4250 | 4593 | 5-30 | 650 | 4607,2 | 132,5 |
| 4300 | 4646 | 5-30 | 658 | 4772,4 | 135,6 |
| 4350 | 4699 | 5-30 | 666 | 4941,5 | 138,7 |
| 4400 | 4752 | 5-30 | 673 | 5114,5 | 141,8 |
| 4450 | 4805 | 5-30 | 681 | 5291,5 | 145,0 |
| 4500 | 4858 | 5-30 | 689 | 5472,5 | 148,2 |
| 4550 | 4910 | 5-30 | 696 | 5657,6 | 151,4 |
| 4600 | 4963 | 5-30 | 704 | 5846,9 | 154,7 |
| 4700 | 5069 | 5-30 | 719 | 6237,9 | 161,4 |
| 4800 | 5175 | 5-30 | 734 | 6646,0 | 168,2 |
| 4900 | 5280 | 5-30 | 750 | 7071,6 | 175,1 |
| 5000 | 5386 | 5-30 | 765 | 7514,9 | 182,2 |
| 5100 | 5492 | 5-30 | 780 | 7976,4 | 189,4 |
| 5200 | 5598 | 5-30 | 796 | 8456,4 | 196,8 |
| 5300 | 5703 | 5-30 | 811 | 8955,2 | 204,3 |
| 5400 | 5809 | 5-30 | 826 | 9473,4 | 211,9 |
| 5500 | 5915 | 5-30 | 842 | 10011,1 | 219,7 |

Note: ● t = Épaisseur de la matière première / Raw material thickness ● Dp = diamètre rondelle / Diameter of blank disc
● Consultez notre commercial pour tolérances dimensionnelles. / Please contact our sales team for dimension tolerances.

FOND DE CUVE A BAS PLAT
DISHED & FLANGED ELLIPTICAL HEADS

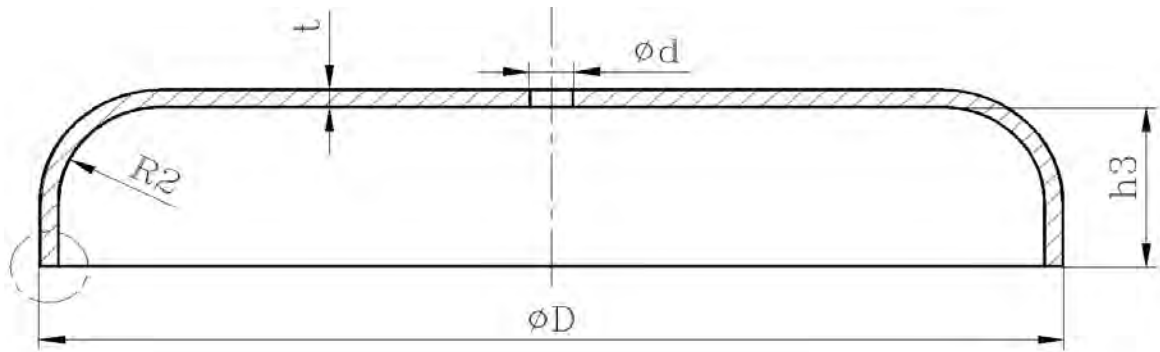

DETAIL - A

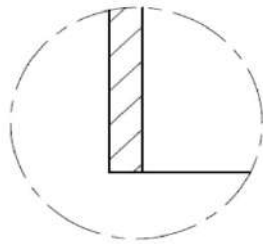

DETAIL - B

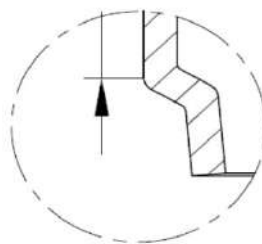

DETAIL - C

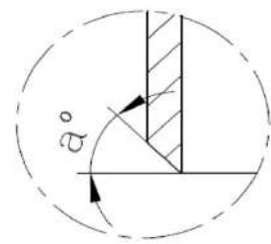

* $D \leq \phi 2000$
 $t \leq 8 \text{ mm}$

$D = \text{max. } 5700 \text{ mm}$

$R2 = 20 - 100$

$t = \text{max. } 30 \text{ mm}$

$$\text{Mass} = (Dp^2 \times 0,785 \times 8/1000000) \times t$$

* t = Épaisseur matière première - Raw material thickness

* Dp = diamètre rondelle - Diameter of blank disc

FOND DE CUVE A TÊTES ELLIPTIQUES, OVAL & À CONE
DISHED & FLANGED ELLIPTICAL HEADS

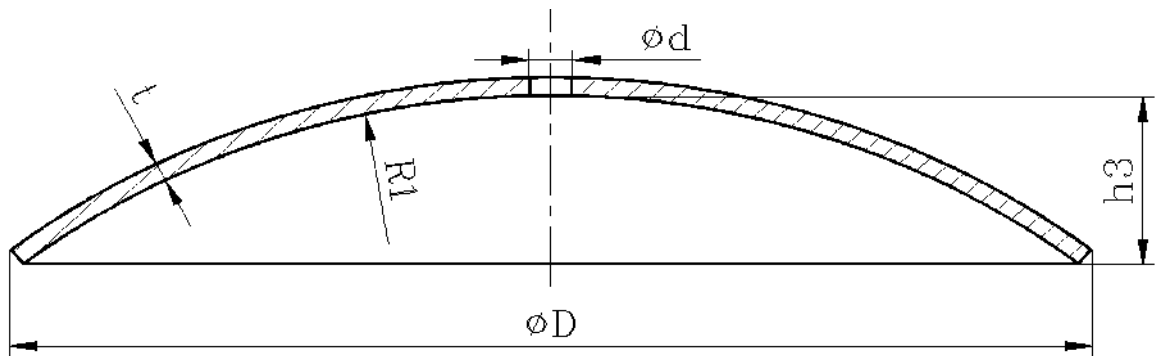

D = max. 5800 mm
R1 = choix du client - Customer request
t = max. 50 mm
Mass = $(Dp^2 \times 0,785 \times 8/1000000) \times t$
*t=Épaisseur matière première - Raw material thickness
*Dp = diamètre rondelle - Diameter of blank disc

FOND DE CUVE A TÊTES ELLIPTIQUES ET À CONE
DISHED & FLANGED ELLIPTICAL HEADS

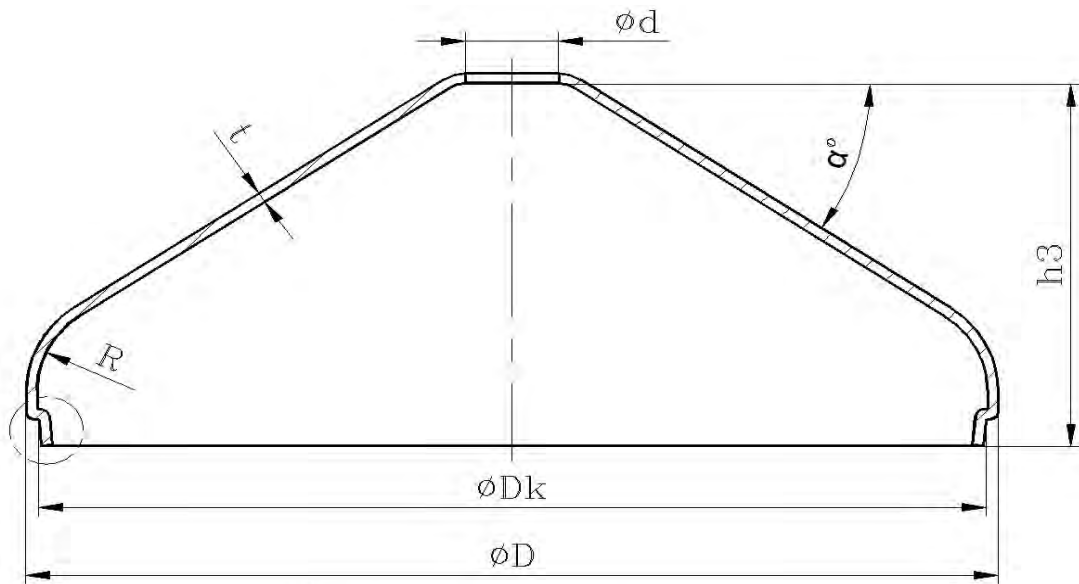

DETAIL - A

DETAIL - B

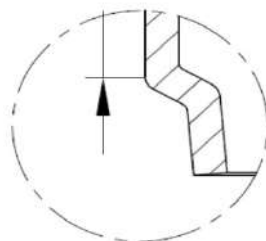
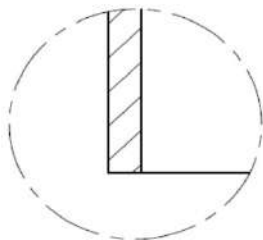

* $D \leq \phi 2000$
* $t \leq 8 \text{ mm}$

$D = 300 - 5000 \text{ mm}$

$R = \text{choix du client} - \text{Customer request}$

$t = \text{max. } 30 \text{ mm}$

$h3 = \text{max. } 1800 \text{ mm}$

$\alpha = \text{choix du client} - \text{Customer request}$

$Mass = (Dp^2 \times 0,785 \times 8/1000000) \times t$

* $t = \text{Épaisseur matière première} - \text{Raw material thickness}$

* $Dp = \text{diamètre rondelle} - \text{Diameter of blank disc}$

FOND DE CUVE A BAS INVERSE
DISHED & FLANGED REVERSED HEADS

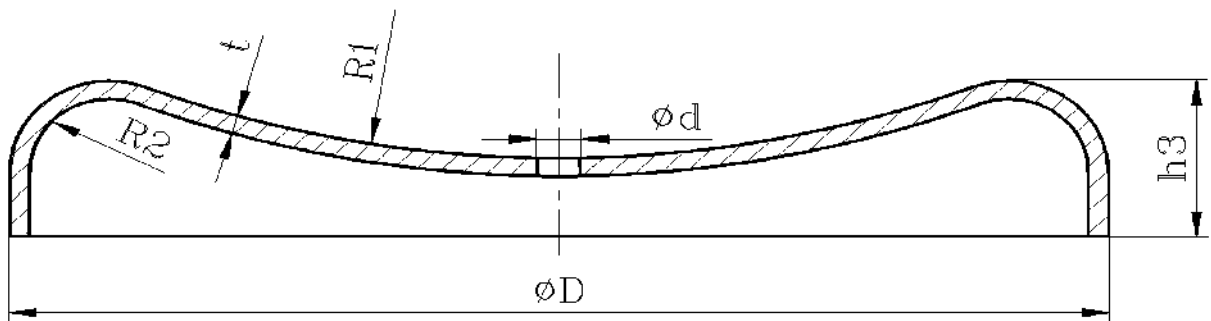

D = max. 5600 mm

R1 = choix du client - Customer request

R2 = 20 - 100

t = max. 30 mm

Mass = $(Dp^2 \times 0,785 \times 8/1000000) \times t$

*t=Épaisseur matière première - Raw material thickness

*Dp = diamètre rondelle - Diameter of blank disc

FOND DE CUVE A TÊTES PLATES ET À CONE
DISHED & FLANGED PLATE HEADS

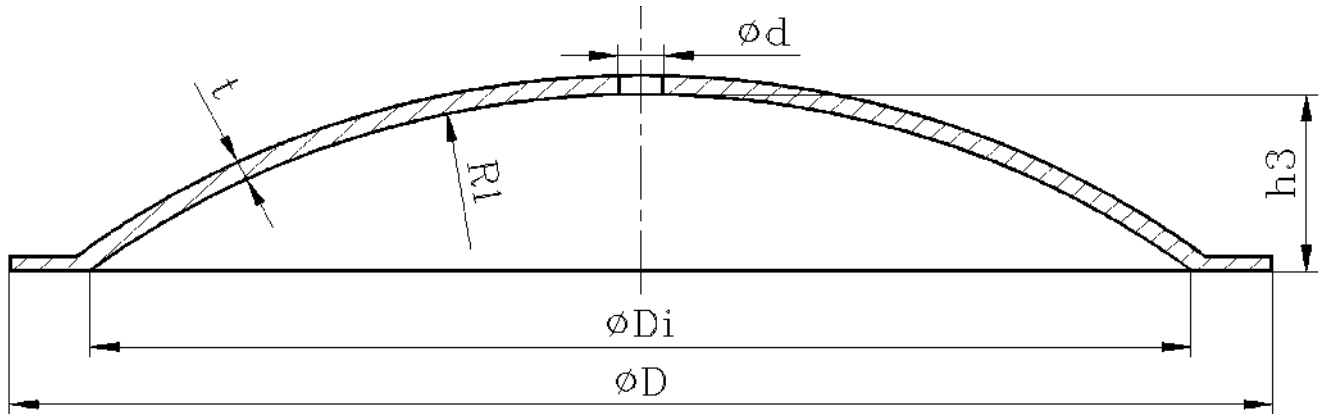

D = max. 5800 mm
R1 = choix du client - Customer request
t = max. 30 mm
Mass = $(Dp^2 \times 0,785 \times 8/1000000) \times t$
*t=Épaisseur matière première - Raw material thickness
*Dp = diamètre rondelle - Diameter of blank disc

SCHEMA DE QUELQUES MODELES

